

# TC7WPB8306L8X, TC7WPB8307L8X

## 1. Functional Description

- Low-Voltage, Low-Power 2-Bit Dual-Supply Bus Switch

## 2. General

The TC7WPB8306L8X and TC7WPB8307L8X are CMOS 2-bit dual-supply bus switches that can provide an interface between two nodes at different voltage levels. These devices can be connected to two independent power supplies.  $V_{CCA}$  supports 1.8-V, 2.5-V and 3.3-V power supplies, whereas  $V_{CCB}$  supports 2.5-V, 3.3-V and 5.0 V power supplies.

Each  $A_n$  terminal has an internal pull-up resistor to  $V_{CCA}$ , and each  $B_n$  terminal has an internal pull-up resistor to  $V_{CCB}$ . And each I/O terminal has a signal level detection circuit which speeds up the low-to-high transition.

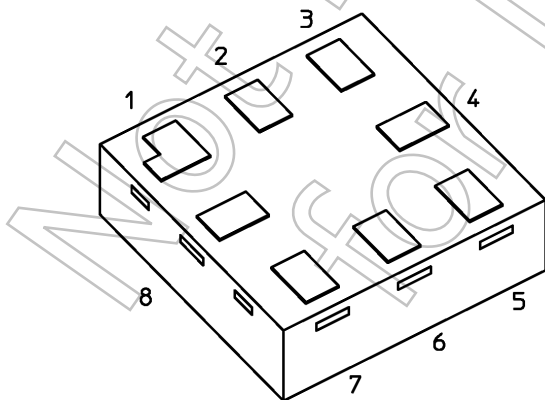
The Output Enable ( $\overline{OE}$ : TC7WPB8307L8X, OE: TC7WPB8306L8X) input is common for all the two-bits of the data lines; thus these device are used as a single two-bits bus switch. For the TC7WPB8306L8X, Output Enable (OE) is active-High: When OE is High, the switch is on; when Low, the switch is off. For the TC7WPB8307L8X, Output Enable ( $\overline{OE}$ ) is active-Low: When  $\overline{OE}$  is Low, the switch is on; when High, the switch is off. All inputs and outputs of the TC7WPB8306L8X and TC7WPB8307L8X can tolerate overvoltage conditions up to 5.5 V. The channels consist of n-type MOSFETs.

All the inputs provide protection against electrostatic discharge.

## 3. Features

- (1) Operating voltage: 1.8 V to 2.5 V / 1.8 V to 3.3 V / 1.8 V to 5.0 V / 2.5 V to 3.3 V / 2.5 V to 5.0 V / 3.3 V to 5.0 V bidirectional interface
- (2) Operating voltage:  $V_{CCA} = 1.65$  to 5.0 V,  $V_{CCB} = 2.3$  to 5.5 V
- (3)  $R_{ON} = 6.5 \Omega$  (typ.)  
(ON-resistance test condition:  $V_{IS} = 0$  V,  $I_{IS} = 10$  mA,  $V_{CCA} = 3.0$  V,  $V_{CCB} = 4.5$  V)
- (4) ESD performance: Machine mode  $\geq \pm 200$  V, Human body model  $\geq \pm 2000$  V
- (5) 5.5-V tolerant function and power-down protection provided on all inputs and outputs.
- (6) Packages: MP8

## 4. Packaging

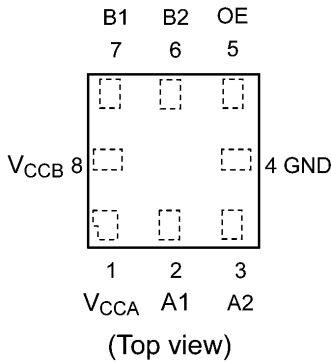


BOTTOM VIEW

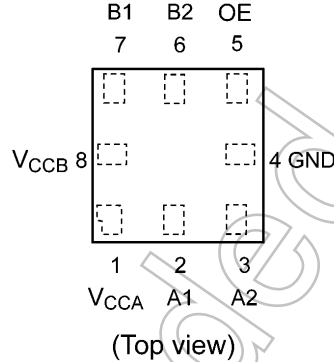
MP8

**5. Pin Assignment**

TC7WPB8306L8X

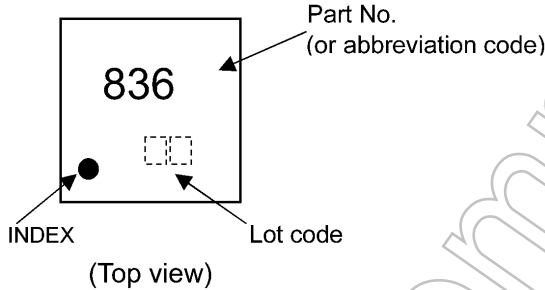


TC7WPB8307L8X

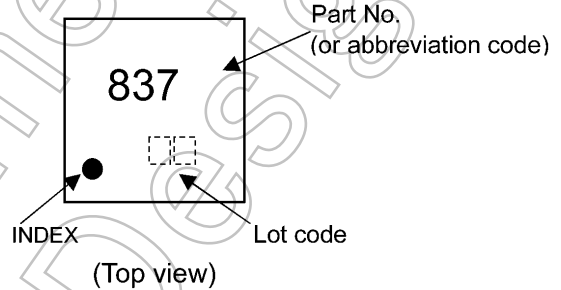


**6. Marking**

TC7WPB8306L8X



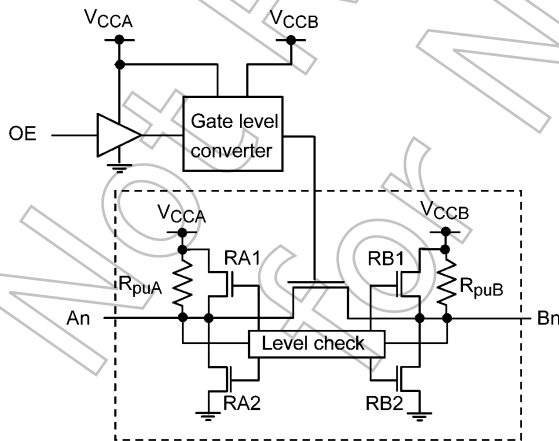
TC7WPB8307L8X



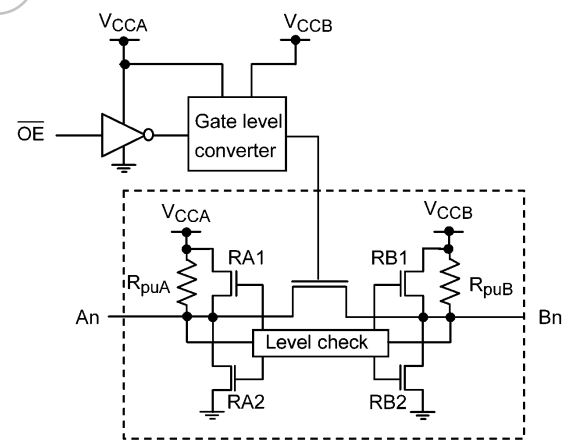
**7. Block Diagram**

One-shot driver circuits (RA1, RB1, RA2 and RB2) of the TC7WPB8306L8X and TC7WPB8307L8X detect either a rising or falling edge on the A or B port. During the rise time, the RA1 and RB1 transistors are turned on for a certain period to speed up a transition from Low to High. Likewise, during the fall time, the RA2 and RB2 transistors are turned on to speed up a transition from High to Low.

TC7WPB8306L8X



TC7WPB8307L8X



**8. Principle of Operation**

**8.1. Truth Table**

| Inputs OE<br>(TC7WPB8306L8X) | Inputs $\overline{OE}$<br>(TC7WPB8307L8X) | Function        |
|------------------------------|---|-----------------|
| H                            | L   | A port = B port |
| L                            | H   | Disconnect      |

**9. Absolute Maximum Ratings (Note)**

| Characteristics                         | Symbol    | Note | Rating      | Unit        |
|---|-----------|------|-------------|-------------|
| Supply voltage                          | $V_{CCA}$ |      | -0.5 to 7.0 | V           |
|   | $V_{CCB}$ |      | -0.5 to 7.0 |             |
| Input voltage ( $\overline{OE}$ , OE)   | $V_{IN}$  |      | -0.5 to 7.0 |             |
| Switch I/O voltage                      | $V_S$     |      | -0.5 to 7.0 |             |
| Clamp diode current                     | $I_{IK}$  |      | -50         | mA          |
| Switch I/O current                      | $I_S$     |      | 64          |             |
| $V_{CC}$ /ground current per supply pin | $I_{CCA}$ |      | $\pm 25$    |             |
|   | $I_{CCB}$ |      | $\pm 25$    |             |
| Power dissipation                       | $P_D$     |      | 300         | mW          |
| Storage temperature                     | $T_{stg}$ |      | -65 to 150  | $^{\circ}C$ |

Note: Exceeding any of the absolute maximum ratings, even briefly, lead to deterioration in IC performance or even destruction.

Using continuously under heavy loads (e.g. the application of high temperature/current/voltage and the significant change in temperature, etc.) may cause this product to decrease in the reliability significantly even if the operating conditions (i.e. operating temperature/current/voltage, etc.) are within the absolute maximum ratings and the operating ranges.

Please design the appropriate reliability upon reviewing the Toshiba Semiconductor Reliability Handbook (“Handling Precautions”/“Derating Concept and Methods”) and individual reliability data (i.e. reliability test report and estimated failure rate, etc).

**10. Operating Ranges (Note)**

| Characteristics                         | Symbol    | Note     | Rating      | Unit        |
|---|-----------|----------|-------------|-------------|
| Supply voltage                          | $V_{CCA}$ | (Note 1) | 1.65 to 5.0 | V           |
|   | $V_{CCB}$ |          | 2.3 to 5.5  |             |
| Input voltage ( $\overline{OE}$ , OE)   | $V_{IN}$  |          | 0 to 5.5    |             |
| Switch I/O voltage                      | $V_S$     |          | 0 to 5.5    |             |
| Operating temperature                   | $T_{opr}$ |          | -40 to 85   | $^{\circ}C$ |
| Input rise time ( $\overline{OE}$ , OE) | $dt/dv$   |          | 0 to 10     | ns/V        |
| Input fall time ( $\overline{OE}$ , OE) | $dt/dv$   |          | 0 to 10     |             |

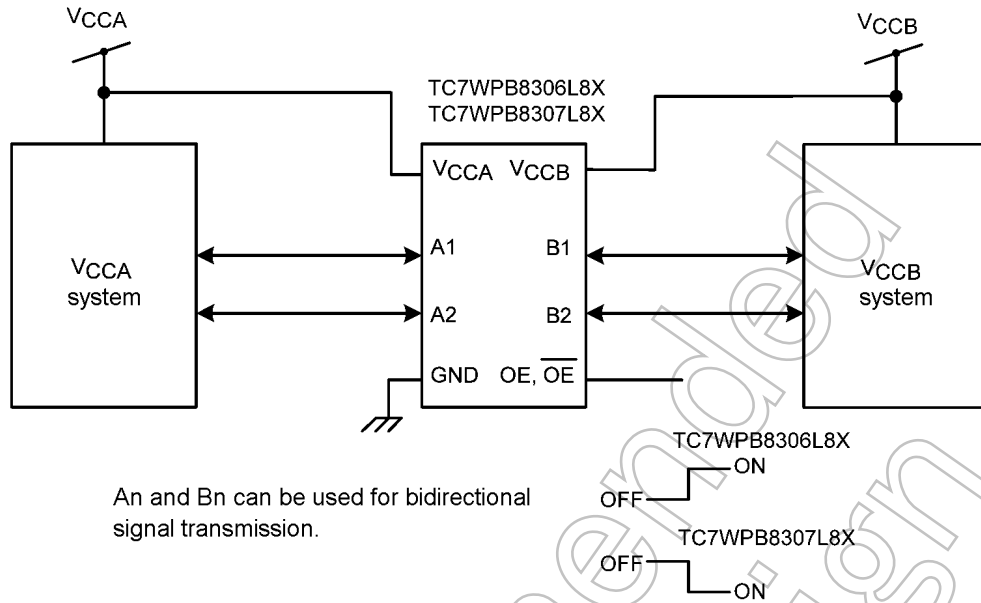
Note : The operating ranges must be maintained to ensure the normal operation of the device.

Unused inputs and bus inputs must be tied to either  $V_{CC}$  or GND.

Note 1: The  $V_{CCA}$  voltage must be lower than the  $V_{CCB}$  voltage.

Not for

11. Application Circuit (Note)



Note:  $V_{CCA} < V_{CCB}$  voltage must be lower than the  $V_{CCB}$  voltage.

Note: Level-shifting functionality is enabled by adding pull-up resistors from An to  $V_{CCA}$  or  $V_{CCB}$  and from Bn to  $V_{CCB}$  or  $V_{CCA}$ , respectively.

Not Recommended for New Design

**12. Electrical Characteristics**

**12.1. DC Characteristics (Unless otherwise specified,  $T_a = -40$  to  $85$  °C)**

| Characteristics                  | Symbol       | Note     | Test Condition   | $V_{CCA}$ (V)   | $V_{CCB}$ (V)    | Min                  | Max                  | Unit       |           |
|----------------------------------|--------------|----------|--|---|------------------|----------------------|----------------------|------------|-----------|
| High-level input voltage         | $V_{IH}$     |          | —  | $1.65 \leq V_{CCA} < 2.3$                                   | $V_{CCA}$ to 5.5 | $0.8 \times V_{CC}$  | —                    | V          |           |
|                                  |              |          |  | $2.3 \leq V_{CCA} < 5.0$                                    | $V_{CCA}$ to 5.5 | $0.7 \times V_{CCA}$ | —                    |            |           |
| Low-level input voltage          | $V_{IL}$     |          | —  | $1.65 \leq V_{CCA} < 2.3$                                   | $V_{CCA}$ to 5.5 | —                    | $0.2 \times V_{CCA}$ | V          |           |
|                                  |              |          |  | $2.3 \leq V_{CCA} < 5.0$                                    | $V_{CCA}$ to 5.5 | —                    | $0.3 \times V_{CCA}$ |            |           |
| ON-resistance                    | $R_{ON}$     | (Note 1) | $V_{IS} = 0$ V, $I_{IS} = 10$ mA<br>See Fig. 13.1.                 | 1.65  | 2.3              | —                    | 24                   | $\Omega$   |           |
|                                  |              |          |  | 2.3   | 3.0              | —                    | 14                   |            |           |
|                                  |              |          |  | 3.0   | 4.5              | —                    | 12                   |            |           |
| Pull-up resistance               | $R_{pu}$     |          | $R_{puA}$<br>$V_{IS} = V_{CCA} - 0.2$ V                            | 1.65  | $V_{CCA}$ to 5.5 | —                    | 40                   | k $\Omega$ |           |
|                                  |              |          |  | 2.3   | $V_{CCA}$ to 5.5 | —                    | 30                   |            |           |
|                                  |              |          |  | 3.0   | $V_{CCA}$ to 5.5 | —                    | 20                   |            |           |
|                                  |              |          | $R_{puB}$<br>$V_{IS} = V_{CCB} - 0.2$ V                            | 1.65  | $V_{CCA}$ to 5.5 | —                    | 40                   |            |           |
|                                  |              |          |  | 2.3   | $V_{CCA}$ to 5.5 | —                    | 30                   |            |           |
|                                  |              |          |  | 3.0   | $V_{CCA}$ to 5.5 | —                    | 20                   |            |           |
| One-shot driver ON-resistance    | $R_{ON(OS)}$ |          | RA1 = ON<br>$V_{IS} = V_{CCA} - 0.2$ V                             | 1.65  | $V_{CCA}$ to 5.5 | —                    | 80                   | $\Omega$   |           |
|                                  |              |          |  | 2.3   | $V_{CCA}$ to 5.5 | —                    | 60                   |            |           |
|                                  |              |          |  | 3.0   | $V_{CCA}$ to 5.5 | —                    | 40                   |            |           |
|                                  |              |          | RA2 = ON<br>$V_{IS} = GND + 0.2$ V                                 | 1.65 to 1.9   | 2.3              | —                    | 40                   |            |           |
|                                  |              |          |  | 1.65 to 2.7   | 3.0              | —                    | 30                   |            |           |
|                                  |              |          |  | 1.65 to 3.6   | 4.5              | —                    | 20                   |            |           |
|                                  |              |          | RB1 = ON<br>$V_{IS} = V_{CCB} - 0.2$ V                             | 1.65 to 1.9   | 2.3              | —                    | 40                   |            |           |
|                                  |              |          |  | 1.65 to 2.7   | 3.0              | —                    | 30                   |            |           |
|                                  |              |          |  | 1.65 to 3.6   | 4.5              | —                    | 20                   |            |           |
|                                  |              |          | RB2 = ON<br>$V_{IS} = GND + 0.2$ V                                 | 1.65 to 1.9   | 2.3              | —                    | 40                   |            |           |
|                                  |              |          |  | 1.65 to 2.7   | 3.0              | —                    | 30                   |            |           |
|                                  |              |          |  | 1.65 to 3.6   | 4.5              | —                    | 20                   |            |           |
| Power-OFF leakage current        | $I_{OFF}$    |          | $A_n, B_n = 0$ to 5.5 V,<br>Per circuit                            | 0   | 0                | —                    | $\pm 1.0$            | $\mu$ A    |           |
| Switch OFF-state leakage current | $I_{SZ}$     |          | $A_n, B_n = 0$ to 5.5 V,<br>$\overline{OE} = V_{CCA}$ , $OE = GND$ | 1.65 to 5.0   | $V_{CCA}$ to 5.5 | —                    | $\pm 1.0$            | $\mu$ A    |           |
| Input leakage current            | $I_{IN}$     |          | $\overline{OE}$ , $OE = 0$ to 5.5 V                                | 1.65 to 5.0   | $V_{CCA}$ to 5.5 | —                    | $\pm 1.0$            | $\mu$ A    |           |
| Quiescent supply current         | $I_{CCA}$    |          | $\overline{OE}$ , $OE = V_{CCA}$ or GND,<br>$I_S = 0$ A            | 1.65 to 5.0   | $V_{CCA}$        | —                    | 1.0                  | $\mu$ A    |           |
|                                  | $I_{CCB}$    |          |  | 1.65 to 5.0   | $V_{CCA}$        | —                    | 1.0                  |            |           |
|                                  | $I_{CCA}$    |          |  | $V_{CCA} \leq \overline{OE}$ , $\leq 5.5$ V,<br>$I_S = 0$ A | 1.65 to 5.0      | $V_{CCA}$            | —                    |            | $\pm 1.0$ |
|                                  | $I_{CCB}$    |          |  |   | 1.65 to 5.0      | $V_{CCA}$            | —                    |            | $\pm 1.0$ |

Note 1: Measured by the voltage drop between A and B pins at the indicated current through the switch.

**12.2. AC Characteristics**

**12.2.1.  $V_{CCA} = 1.8 \pm 0.15 \text{ V}$**

(Unless otherwise specified,  $T_a = -40 \text{ to } 85 \text{ }^\circ\text{C}$ , Input:  $t_r = t_f = 2.0 \text{ ns}$ ,  $f = 10 \text{ kHz}$ )

| Characteristics                    | Symbol            | Note     | Test Condition       | $V_{CCB}$ (V) | Min | Max | Unit |
|------------------------------------|-------------------|----------|----------------------|---------------|-----|-----|------|
| Propagation delay time (bus → bus) | $t_{PLH}/t_{PHL}$ | (Note 1) | See Fig. 14.1, 14.3. | $2.5 \pm 0.2$ | —   | 25  | ns   |
|                                    |                   |          |                      | $2.5 \pm 0.2$ | —   | 10  |      |
| 3-state output enable time         | $t_{PZL}/t_{PZH}$ |          | See Fig. 14.2, 14.4. | $2.5 \pm 0.2$ | —   | 21  |      |
| 3-state output disable time        | $t_{PLZ}/t_{PHZ}$ |          | See Fig. 14.2, 14.4. | $2.5 \pm 0.2$ | —   | 23  |      |

Note 1: This parameter is guaranteed by design but is not tested. The bus switch contributes no propagation delay other than the RC delay of the typical On resistance of the switch and the 15 pF load capacitance, when driven by an ideal voltage the source (zero output impedance).

**12.2.2.  $V_{CCA} = 2.5 \pm 0.2 \text{ V}$**

(Unless otherwise specified,  $T_a = -40 \text{ to } 85 \text{ }^\circ\text{C}$ , Input:  $t_r = t_f = 2.0 \text{ ns}$ ,  $f = 10 \text{ kHz}$ )

| Characteristics                    | Symbol            | Note     | Test Condition       | $V_{CCB}$ (V) | Min | Max | Unit |
|------------------------------------|-------------------|----------|----------------------|---------------|-----|-----|------|
| Propagation delay time (bus → bus) | $t_{PLH}/t_{PHL}$ | (Note 1) | See Fig. 14.1, 14.3. | $3.3 \pm 0.3$ | —   | 18  | ns   |
|                                    |                   |          |                      | $3.3 \pm 0.3$ | —   | 7   |      |
| 3-state output enable time         | $t_{PZL}/t_{PZH}$ |          | See Fig. 14.2, 14.4. | $3.3 \pm 0.3$ | —   | 17  |      |
| 3-state output disable time        | $t_{PLZ}/t_{PHZ}$ |          | See Fig. 14.2, 14.4. | $3.3 \pm 0.3$ | —   | 19  |      |

Note 1: This parameter is guaranteed by design but is not tested. The bus switch contributes no propagation delay other than the RC delay of the typical On resistance of the switch and the 15 pF load capacitance, when driven by an ideal voltage the source (zero output impedance).

**12.2.3.  $V_{CCA} = 2.5 \pm 0.2 \text{ V}$**

(Unless otherwise specified,  $T_a = -40 \text{ to } 85 \text{ }^\circ\text{C}$ , Input:  $t_r = t_f = 2.0 \text{ ns}$ ,  $f = 10 \text{ kHz}$ )

| Characteristics                    | Symbol            | Note     | Test Condition       | $V_{CCB}$ (V) | Min | Max | Unit |
|------------------------------------|-------------------|----------|----------------------|---------------|-----|-----|------|
| Propagation delay time (bus → bus) | $t_{PLH}/t_{PHL}$ | (Note 1) | See Fig. 14.1, 14.3. | $5.0 \pm 0.5$ | —   | 15  | ns   |
|                                    |                   |          |                      | $5.0 \pm 0.5$ | —   | 9   |      |
| 3-state output enable time         | $t_{PZL}/t_{PZH}$ |          | See Fig. 14.2, 14.4. | $5.0 \pm 0.5$ | —   | 13  |      |
| 3-state output disable time        | $t_{PLZ}/t_{PHZ}$ |          | See Fig. 14.2, 14.4. | $5.0 \pm 0.5$ | —   | 5   |      |

Note 1: This parameter is guaranteed by design but is not tested. The bus switch contributes no propagation delay other than the RC delay of the typical On resistance of the switch and the 15 pF load capacitance, when driven by an ideal voltage the source (zero output impedance).

**12.2.4.  $V_{CCA} = 3.3 \pm 0.3 \text{ V}$**

(Unless otherwise specified,  $T_a = -40 \text{ to } 85 \text{ }^\circ\text{C}$ , Input:  $t_r = t_f = 2.0 \text{ ns}$ ,  $f = 10 \text{ kHz}$ )

| Characteristics                    | Symbol            | Note     | Test Condition       | $V_{CCB}$ (V) | Min | Max | Unit |
|------------------------------------|-------------------|----------|----------------------|---------------|-----|-----|------|
| Propagation delay time (bus → bus) | $t_{PLH}/t_{PHL}$ | (Note 1) | See Fig. 14.1, 14.3. | $5.0 \pm 0.5$ | —   | 10  | ns   |
|                                    |                   |          |                      | $5.0 \pm 0.5$ | —   | 6   |      |
| 3-state output enable time         | $t_{PZL}/t_{PZH}$ |          | See Fig. 14.2, 14.4. | $5.0 \pm 0.5$ | —   | 9   |      |
| 3-state output disable time        | $t_{PLZ}/t_{PHZ}$ |          | See Fig. 14.2, 14.4. | $5.0 \pm 0.5$ | —   | 11  |      |

Note 1: This parameter is guaranteed by design but is not tested. The bus switch contributes no propagation delay other than the RC delay of the typical On resistance of the switch and the 15 pF load capacitance, when driven by an ideal voltage the source (zero output impedance).

**12.3. Timing Requirements**

**12.3.1.  $V_{CCA} = 1.8 \pm 0.15 \text{ V}$**

(Unless otherwise specified,  $T_a = -40 \text{ to } 85 \text{ }^\circ\text{C}$ , Input:  $t_r = t_f = 2.0 \text{ ns}$ )

| Characteristics             | Symbol | Test Condition         | $V_{CCB}$ (V) | Min | Max | Unit |
|-----------------------------|--------|------------------------|---------------|-----|-----|------|
| Pulse duration (data input) | $t_w$  | —                      | 2.3           | —   | 47  | ns   |
|                             |        |                        | 3.0           | —   | 45  |      |
|                             |        |                        | 4.5           | —   | 41  |      |
| Data rate                   | $f_D$  | $C_L = 15 \text{ pF}$  | 2.3           | —   | 21  | Mbps |
|                             |        |                        | 3.0           | —   | 22  |      |
|                             |        |                        | 4.5           | —   | 24  |      |
|                             |        | $C_L = 150 \text{ pF}$ | 2.3           | —   | 2.9 |      |
|                             |        |                        | 3.0           | —   | 3.1 |      |
|                             |        |                        | 4.5           | —   | 3.4 |      |

**12.3.2.  $V_{CCA} = 2.5 \pm 0.2 \text{ V}$**

(Unless otherwise specified,  $T_a = -40 \text{ to } 85 \text{ }^\circ\text{C}$ , Input:  $t_r = t_f = 2.0 \text{ ns}$ )

| Characteristics             | Symbol | Test Condition         | $V_{CCB}$ (V) | Min | Max | Unit |
|-----------------------------|--------|------------------------|---------------|-----|-----|------|
| Pulse duration (data input) | $t_w$  | —                      | 3.0           | —   | 45  | ns   |
|                             |        |                        | 4.5           | —   | 41  |      |
| Data rate                   | $f_D$  | $C_L = 15 \text{ pF}$  | 3.0           | —   | 22  | Mbps |
|                             |        |                        | 4.5           | —   | 24  |      |
|                             |        | $C_L = 150 \text{ pF}$ | 3.0           | —   | 3.1 |      |
|                             |        |                        | 4.5           | —   | 3.4 |      |

**12.3.3.  $V_{CCA} = 3.3 \pm 0.3 \text{ V}$**

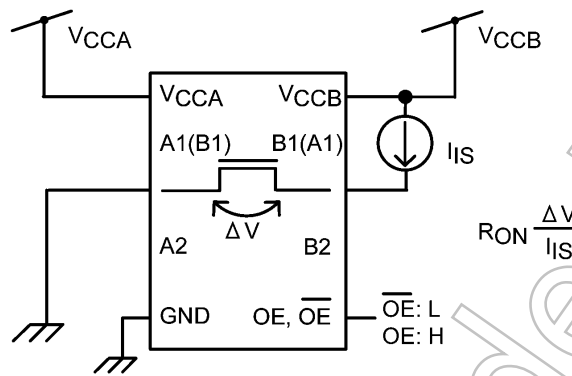
(Unless otherwise specified,  $T_a = -40 \text{ to } 85 \text{ }^\circ\text{C}$ , Input:  $t_r = t_f = 2.0 \text{ ns}$ )

| Characteristics             | Symbol | Test Condition         | $V_{CCB}$ (V) | Min | Max | Unit |
|-----------------------------|--------|------------------------|---------------|-----|-----|------|
| Pulse duration (data input) | $t_w$  | —                      | 4.5           | —   | 41  | ns   |
| Data rate                   | $f_D$  | $C_L = 15 \text{ pF}$  | 4.5           | —   | 24  | Mbps |
|                             |        | $C_L = 150 \text{ pF}$ | 4.5           | —   | 3.4 |      |

**12.4. Capacitive Characteristics (Unless otherwise specified,  $T_a = 25 \text{ }^\circ\text{C}$ )**

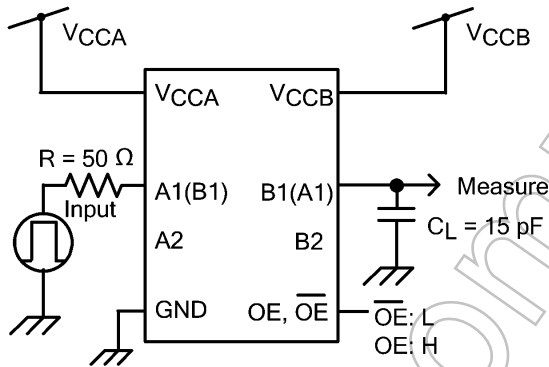
| Characteristics                           | Part Number   | Symbol    | Test Condition                                | $V_{CCA}$ (V) | $V_{CCB}$ (V) | Typ. | Unit |
|---|---------------|-----------|---|---------------|---------------|------|------|
| Input capacitance ( $\overline{OE}$ , OE) |               | $C_{IN}$  | —   | 3.3           | 3.3           | 4    | pF   |
| Switch terminal OFF-capacitance           | TC7WPB8306L8X | $C_{I/O}$ | $\overline{OE}=\text{GND}, V_{I/O}=0\text{V}$ | 3.3           | 3.3           | 10   |      |
|   | TC7WPB8307L8X |           | $\overline{OE}=V_{CC}, V_{I/O}=0\text{V}$     | 3.3           | 3.3           | 10   |      |
| Switch terminal ON-capacitance            | TC7WPB8306L8X | $C_{I/O}$ | $\overline{OE}=V_{CC}, V_{I/O}=0\text{V}$     | 3.3           | 3.3           | 20   |      |
|   | TC7WPB8307L8X |           | $\overline{OE}=\text{GND}, V_{I/O}=0\text{V}$ | 3.3           | 3.3           | 20   |      |

**13. DC Test Circuit**

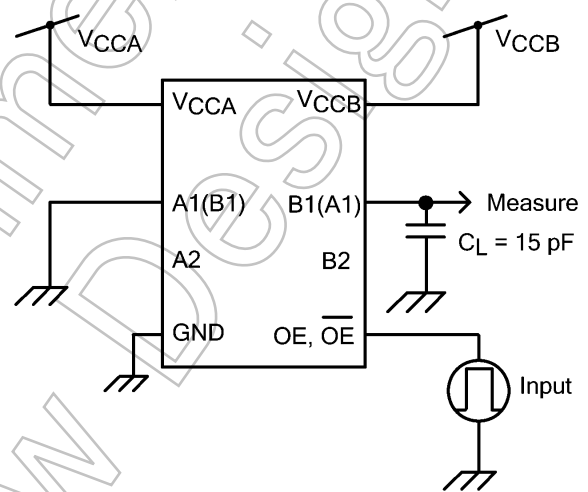


**Fig. 13.1 ON-resistance Test Circuits**

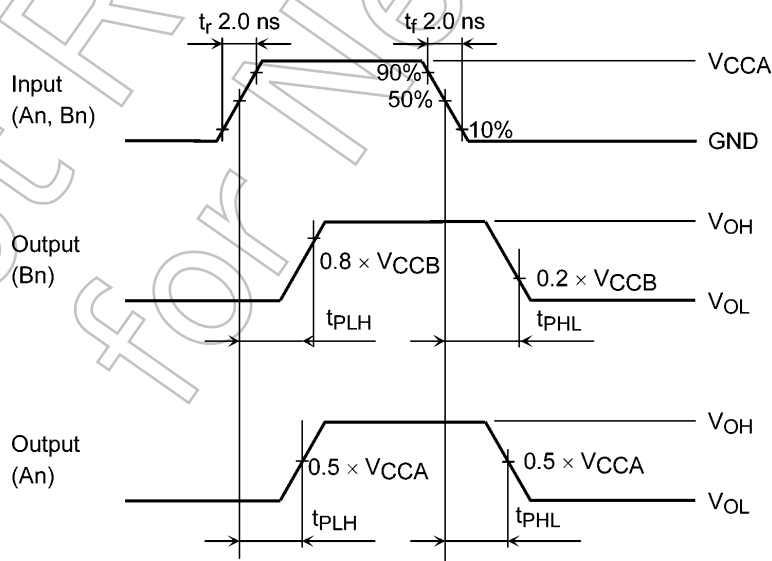
**14. AC Test Circuits/Waveform**



**Fig. 14.1 t<sub>PLH</sub>, t<sub>PHL</sub> Test Circuits**



**Fig. 14.2 t<sub>PLZ</sub>, t<sub>PZL</sub> Test Circuits**



**Fig. 14.3 AC Waveform of t<sub>PLH</sub>, t<sub>PHL</sub>**

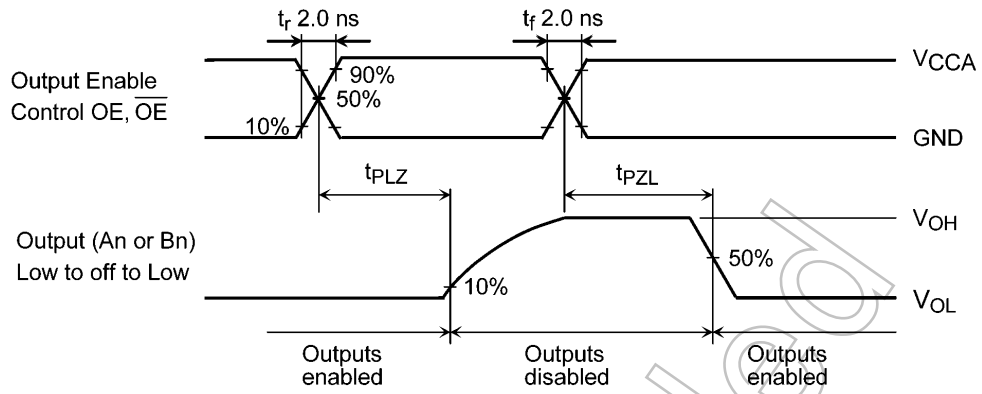
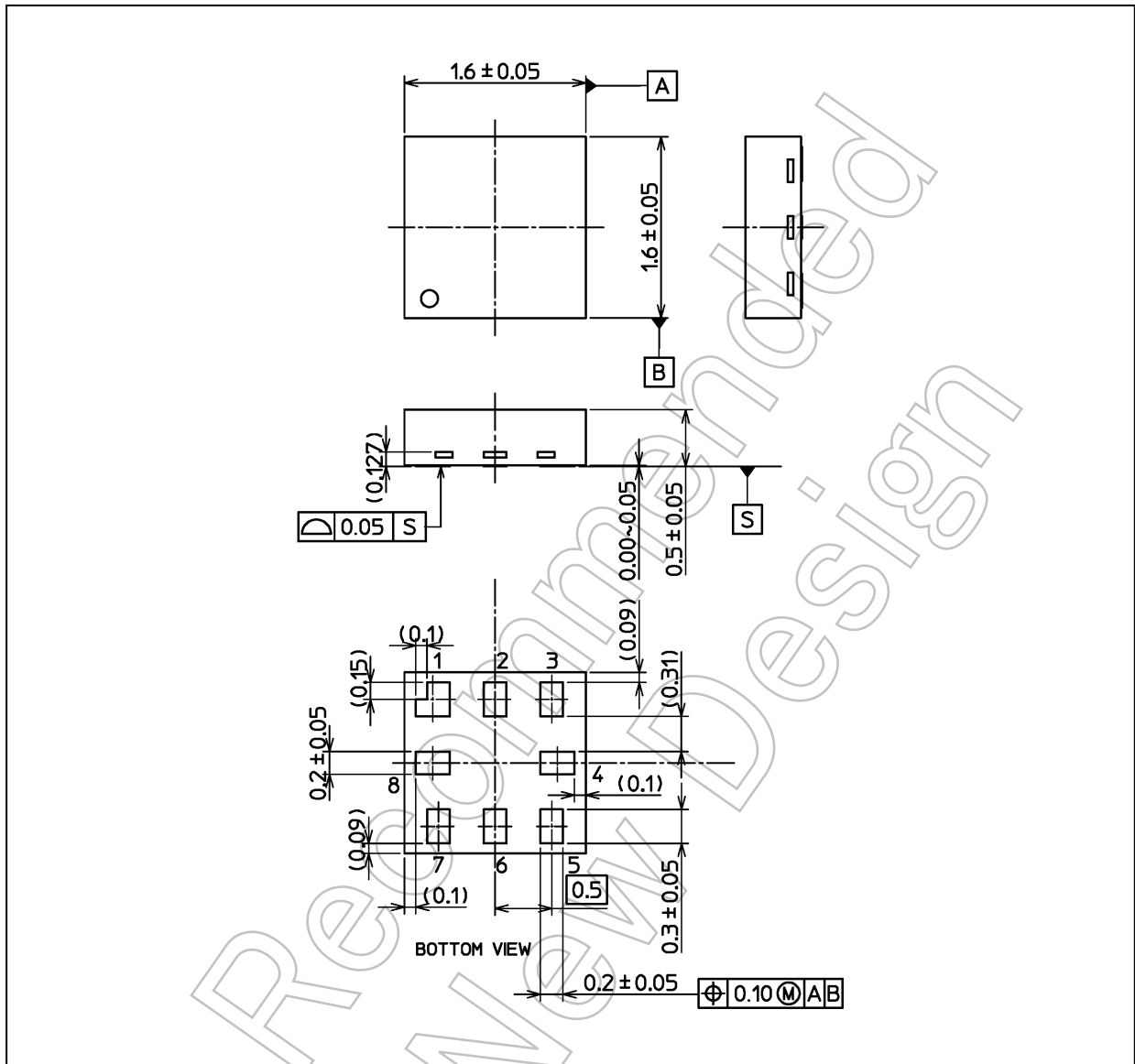


Fig. 14.4 AC Waveform of  $t_{PLZ}$ ,  $t_{PZL}$

Not Recommended for New Design

Package Dimensions

Unit: mm



Weight: 0.0039 g (typ.)

|                                 |
|---------------------------------|
| Package Name(s)                 |
| TOSHIBA: P-UFLGA8-0202-0.50-002 |
| Nickname: MP8                   |

## RESTRICTIONS ON PRODUCT USE

- Toshiba Corporation, and its subsidiaries and affiliates (collectively "TOSHIBA"), reserve the right to make changes to the information in this document, and related hardware, software and systems (collectively "Product") without notice.
- This document and any information herein may not be reproduced without prior written permission from TOSHIBA. Even with TOSHIBA's written permission, reproduction is permissible only if reproduction is without alteration/omission.
- Though TOSHIBA works continually to improve Product's quality and reliability, Product can malfunction or fail. Customers are responsible for complying with safety standards and for providing adequate designs and safeguards for their hardware, software and systems which minimize risk and avoid situations in which a malfunction or failure of Product could cause loss of human life, bodily injury or damage to property, including data loss or corruption. Before customers use the Product, create designs including the Product, or incorporate the Product into their own applications, customers must also refer to and comply with (a) the latest versions of all relevant TOSHIBA information, including without limitation, this document, the specifications, the data sheets and application notes for Product and the precautions and conditions set forth in the "TOSHIBA Semiconductor Reliability Handbook" and (b) the instructions for the application with which the Product will be used with or for. Customers are solely responsible for all aspects of their own product design or applications, including but not limited to (a) determining the appropriateness of the use of this Product in such design or applications; (b) evaluating and determining the applicability of any information contained in this document, or in charts, diagrams, programs, algorithms, sample application circuits, or any other referenced documents; and (c) validating all operating parameters for such designs and applications. **TOSHIBA ASSUMES NO LIABILITY FOR CUSTOMERS' PRODUCT DESIGN OR APPLICATIONS.**
- **PRODUCT IS NEITHER INTENDED NOR WARRANTED FOR USE IN EQUIPMENTS OR SYSTEMS THAT REQUIRE EXTRAORDINARILY HIGH LEVELS OF QUALITY AND/OR RELIABILITY, AND/OR A MALFUNCTION OR FAILURE OF WHICH MAY CAUSE LOSS OF HUMAN LIFE, BODILY INJURY, SERIOUS PROPERTY DAMAGE AND/OR SERIOUS PUBLIC IMPACT ("UNINTENDED USE").** Except for specific applications as expressly stated in this document, Unintended Use includes, without limitation, equipment used in nuclear facilities, equipment used in the aerospace industry, medical equipment, equipment used for automobiles, trains, ships and other transportation, traffic signaling equipment, equipment used to control combustions or explosions, safety devices, elevators and escalators, devices related to electric power, and equipment used in finance-related fields. **IF YOU USE PRODUCT FOR UNINTENDED USE, TOSHIBA ASSUMES NO LIABILITY FOR PRODUCT.** For details, please contact your TOSHIBA sales representative.
- Do not disassemble, analyze, reverse-engineer, alter, modify, translate or copy Product, whether in whole or in part.
- Product shall not be used for or incorporated into any products or systems whose manufacture, use, or sale is prohibited under any applicable laws or regulations.
- The information contained herein is presented only as guidance for Product use. No responsibility is assumed by TOSHIBA for any infringement of patents or any other intellectual property rights of third parties that may result from the use of Product. No license to any intellectual property right is granted by this document, whether express or implied, by estoppel or otherwise.
- **ABSENT A WRITTEN SIGNED AGREEMENT, EXCEPT AS PROVIDED IN THE RELEVANT TERMS AND CONDITIONS OF SALE FOR PRODUCT, AND TO THE MAXIMUM EXTENT ALLOWABLE BY LAW, TOSHIBA (1) ASSUMES NO LIABILITY WHATSOEVER, INCLUDING WITHOUT LIMITATION, INDIRECT, CONSEQUENTIAL, SPECIAL, OR INCIDENTAL DAMAGES OR LOSS, INCLUDING WITHOUT LIMITATION, LOSS OF PROFITS, LOSS OF OPPORTUNITIES, BUSINESS INTERRUPTION AND LOSS OF DATA, AND (2) DISCLAIMS ANY AND ALL EXPRESS OR IMPLIED WARRANTIES AND CONDITIONS RELATED TO SALE, USE OF PRODUCT, OR INFORMATION, INCLUDING WARRANTIES OR CONDITIONS OF MERCHANTABILITY, FITNESS FOR A PARTICULAR PURPOSE, ACCURACY OF INFORMATION, OR NONINFRINGEMENT.**
- Do not use or otherwise make available Product or related software or technology for any military purposes, including without limitation, for the design, development, use, stockpiling or manufacturing of nuclear, chemical, or biological weapons or missile technology products (mass destruction weapons). Product and related software and technology may be controlled under the applicable export laws and regulations including, without limitation, the Japanese Foreign Exchange and Foreign Trade Law and the U.S. Export Administration Regulations. Export and re-export of Product or related software or technology are strictly prohibited except in compliance with all applicable export laws and regulations.
- Please contact your TOSHIBA sales representative for details as to environmental matters such as the RoHS compatibility of Product. Please use Product in compliance with all applicable laws and regulations that regulate the inclusion or use of controlled substances, including without limitation, the EU RoHS Directive. **TOSHIBA ASSUMES NO LIABILITY FOR DAMAGES OR LOSSES OCCURRING AS A RESULT OF NONCOMPLIANCE WITH APPLICABLE LAWS AND REGULATIONS.**